

GPRS BASED REMOTE MONITORING SYSTEM TO SUPPORT LOGISTIC DECISIONS

JÓZSEF KONYHA¹–TAMÁS BÁNYAI²

Abstract: The increased complexity of business behaviour led to the appearance of new techniques, tools and technologies to fulfil market demands. The need for managing networked logistics or global supply chain is recognised due to the importance of the optimal control of logistic functions, such as purchasing, production, distribution and recycling. There are two wide categories of tools that support the development and control of logistic systems: design techniques and IT solutions. Unfortunately, a huge number of production and service companies do not possess all advantages of IT solutions and they continue their quest in improving their business processes without available up-to-date technologies. Wireless based data acquisition technologies are the focus of a huge number of research papers but in the field of logistics these technologies are not widely used. Within the frame of this paper authors are focusing on the IT solutions, especially on the General Packet Radio Service based remote monitoring. They describe the composition and the operation principle of the remote monitoring system.

Keywords: general packet radio service, logistics, optimisation, remote monitoring

1. Introduction

Logistics has, by today, become an important success factor in modern market economies. Logistics undergoes constant development even today; the process motivated by an increasingly fierce competition among economic actors, with victory to be won by the one that satisfies customers' needs the fastest among all, ensuring the quality required by the customer, at minimum costs. Companies therefore see it as their top duty to continuously increase the standards of their logistic services. A logistic system – according to Cselényi – is a closed process that contains material flow – playing a major role in the value-adding and value-preserving chain of purchasing, production, service, distribution, use and recycling – along with the related flow of information, energy, labour, value and money handled in an integrated manner [1]. The most important logistic objectives may be formulated on the basis of basic logistic principles whereby the effectiveness of production and service provision processes may be increased: reducing delivery deadlines and throughput times; maximum use of capacities; reducing stocks and expenses; increasing clarity; creating and increasing flexibility; generating low environmental load; applying environmentally friendly technologies; achieving high transportation capacities; improving client satisfaction and effectiveness.

In the course of investigating logistic processes the essential objective is the analysis of the current situation, and thereby the identification of the bottlenecks and deficiencies in the system. The modelling techniques define the characteristic solutions methods of logistic systems to identify bottlenecks and deficiencies [2]. The development objectives of the logistic system can be determined only in the light of the deficiencies of the current system.

¹ MSc., University of Miskolc
konyha@afki.hu

² PhD., University of Miskolc
alttamas@uni-miskolc.hu

H-3515 Miskolc-Egyetemváros, Hungary

Objectives concerning the development of logistic processes essentially focus on four areas (see Fig. 1.).

These four areas are the followings:

- technical: improving the technical standards, better utilising capacities, reducing energy consumption;
- human resources: development of working conditions, further training of staff, creation of pay-roll system;
- organisation: developing the standards of organisation, development of information flow, improvement of standard of transportation services;
- economy: reducing logistic costs, increasing income and profit, reducing stocks, reducing investment.

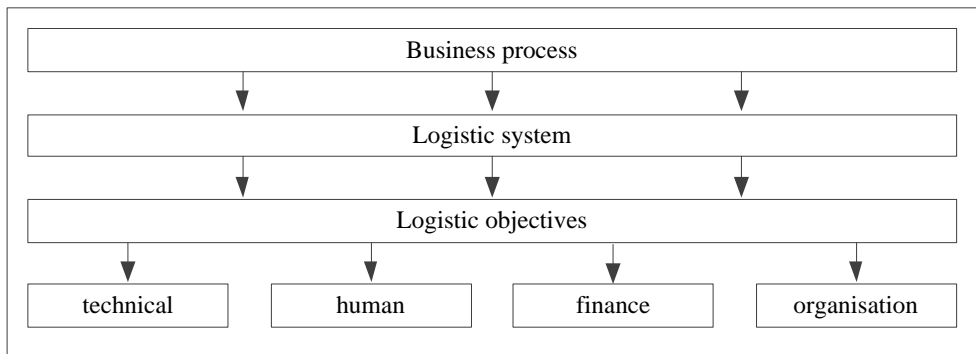

Figure 1. From business process to the impact area of logistic objectives

A fundamental task in managing a logistics system is gathering the information required for decisions and strategies. Such essential information necessary for managing the logistic system is the following:

- reaching a specific place, location, and assumption of a given position by tools performing material flow, exiting such place/position, and transiting a given point of the system;
- reaching a particular area, place, and assumption of a place of work pieces, and products, and exiting such place/position;
- state of storage facilities, warehouses;
- commencement, and completion of movements/operations;
- approaching a certain object by a given distance;
- following the transportation route, i.e. the path of material flow;
- features, and codes of the product, loading units, and transportation tools;
- signs, and codes of major route points;
- data and codes held on various records;
- weight and number of items / amount of material moved;
- speed and acceleration of the transport vehicle, and material being moved.

Information gathering in the logistic system may take place through the following:

- human interaction: observation, processing of records, semi-automatic data collection (e.g. manual code reading, entry in data collection unit by means of keyboard);
- automation: automatic reading of codes with the help of sensors, and measuring elements.

Within the frame of this paper authors are focusing on the automatic data acquisition and transmission technology, which supports logistics related decision making systems and tools.

2. Literature overview

Service and production companies have the same design and operation problems and the solution methods and tools are also the same [3], but the production cost competition of production companies and the service cost competition of service companies are replaced by supply chain cost competition. Local solutions and singular, isolated companies are changed by integrated processes called supply chain [4].

The integration of supply chain members is based on the use of ITC tools and solutions [5]. The supply chain management includes as a key element the information technologies (ITC system, control and automation, forecasting, controlling) and these technologies support the transport management, warehousing and inventory management, packaging and containerisation, production management, total quality management, maintenance management, 3PL and 4PL³ management [6].

An efficient supply chain needs an integrated approach where all elements of logistics from the raw material purchasing to the distribution of final products to the customers are integrated and balanced by the help of ITC solutions. The closed loop economy, which includes the purchasing, production, distribution and recycling processes of value making chain makes it more complicated, because the inverse processes of logistics are stochastic; forecasting and remote monitoring of logistic operations influence the quality of design and control of business processes [7].

The wireless solutions become more and more important and the adoption of these up-to-date technologies (4G, GPRS, RFID) is growing permanently despite the costs of investment is in downturn [8]. Companies recognised the fact, that information is crucial success factor; the right information from the right place to the right place, in the right time and quality becomes the main power source.

The most important benefit of these technologies is that companies can be more coordinated and integrated because of the real-time data acquisition and dynamic strategy adoption. The e-business, e-commerce, on-demand cooperation, event driven decision support systems and virtual organisation industrial paradigms are based on these technologies both in the field of production and services [9].

The RFID technology offers useful solutions in the field of logistics. RFID-based logistics solutions can increase the capacity, quality and availability of logistic operations,

³In the terminology 1PL means the shipper or the consignee, the 2PL abbreviation is for carriers. 3PL providers are companies providing service to customers and 4PL providers are consulting companies.

and reduce the mistakes of logistics operations [10]. The enhancement of flexibility and availability of logistics systems can be enhanced by the help of the combination of RFID technologies and artificial intelligence [11]. A huge number of logistics related business processes need real time solutions to solve the real time decision making problems. Some research works propose solutions using RFID technology integrated with GPS, GSM or GPRS. For example in the case of vehicle tracking and load balancing problems RFID tags are used to identify the goods, weight sensors measure the load weight and GPS, GSM or GPRS is used to track vehicles [12]. The use of GPRS technology is a quite new area in the field of logistics. The remote monitoring of logistics processes can be realised by the support of GSM or GPRS. Within the frame of this paper, we are focusing on the GPRS. There are two main streams of the research works according to GRPS technology. The first mainstream focuses on the development of technologies and the second main stream describes application possibilities. Within the frame of this literature review, we are focusing on the application related sources. The first field of applications is the location management. The GSM based location management has been researched extensively, but GPRS becomes more and more importance because tracking of mobiles in the GPRS is made through routing and location area [13]. The second field of application is the support of remote monitoring systems: water quality monitoring [14, 15], monitoring of heat exchange station [16], checking and ticketing according to the specific requirements of passengers [17].

There are novel tools (six sigma quality, employee involvement, factory automation, design for manufacturability and lean philosophy) by the aid of which it is possible to support the realization of critical success factors of enterprises. The integration of these tools can increase the efficiency of them. As integration tool, the enterprise resource planning systems (ERP) are the most plausible and they can be also used to integrate the above mentioned ITC technologies, decision making processes and physical operations of the logistic system [18].

3. Integration of GPRS based remote monitoring system and ERP

SMEs and multinational companies use ERP solutions⁴. The primary candidates for ERP software were SAP (22%), Oracle (19%), Microsoft Business Solutions (14), Abas (5%). 61% of the companies are using traditional ERP solutions. 14 percent of companies are using ERP solutions delivered as Software as a Service (SaaS). Although the best cloud vendors can deliver superior security and reliability than most internal IT departments, market does not prefer ERP cloud solutions, 12% of the users prefer cloud solutions [19]. The most important logistics related modules of ERP systems are the followings: controlling, material management⁵, sales and distribution, production management⁶, quality

⁴ There are two main streams of research works in the field of enterprise resource planning and enterprise systems. The first main stream of the sources uses the following definition for ERP: "Enterprise resource planning is a business management software—usually a suite of integrated applications—that a company can use to store and manage data from every stage of business, including product planning, cost and development, manufacturing, marketing and sales, inventory management, shipping and payment" [20]. The second main stream makes difference between enterprise resource planning and enterprise systems. Enterprise resource planning includes the enterprise software and the operation strategy of the company. Enterprise systems are only the IT solutions for ERP (SAP, ORACLE, etc.) [21, 22].

⁵Material management includes purchasing, inventory and warehouse management.

management, plant maintenance, human resources. The decision making system of ERP supports logistics related ERP modules to find the best process parameters to optimise business processes. The decision making system is based on design and control methods, expert systems and special tools. One of the most important special tools is the lean philosophy, which can be applied in the different field of business processes: manufacturing, process planning, system integration, human resources, financing, purchasing and distribution.

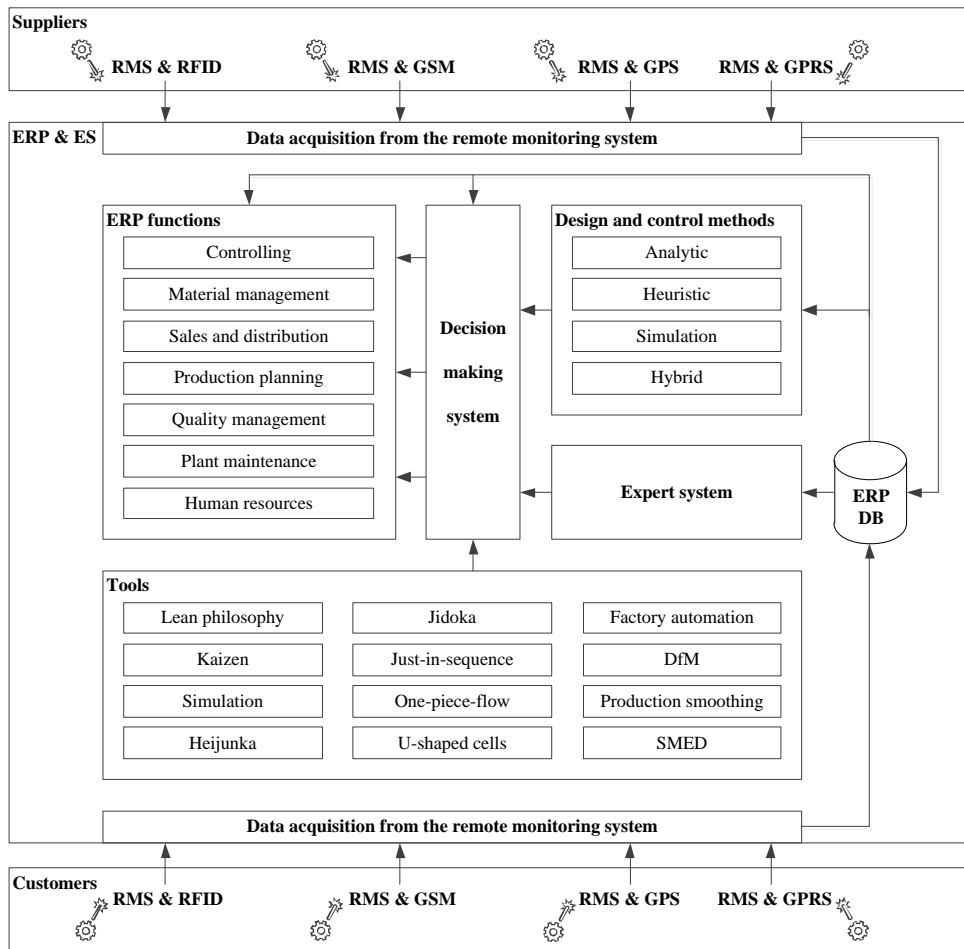

Figure 2. RMS integration in ERP

The design and control methods are in the case of small sized problems analytical [23]. In the case of NP-hard problems heuristic methods [24, 25] and scenario analysis based simulation methods are used [26], combined with analytical methods (hybrid solutions).

⁶Product and design, production process, production capacity, production planning, production control, quality and cost control, maintenance replacement.

The remote monitoring system can be placed in different regions of supply chain to collect data to support the real time decision making for logistics related modules of ERP.

4. ITC background of GPRS based RMS

The geographical coverage of the GSM cellular network is more than 99% in Hungary and due to this high coverage we are able to build countrywide systems. Under good conditions, the average response time of the GPRS network is less than a second. Within the frame of this chapter a GPRS based data acquisition and control IT system is introduced.

4.1. System Architecture. The system consists of two main parts: the central system and the remote systems. The two parts of the system are communicating on a virtual private network (VPN).

The field-installed remote system is responsible for the acquisition of data from different sensors. After the acquisition of data, the RTU (remote terminal unit) send data to the central system. The remote system can control several devices at the same time also (motors, relays, switches).

The central system is a high-performance server with enough memory to process the incoming data quickly. Thereafter data is stored in a MySQL database server. After storage, it provides information in different formats (e.g. diagrams, tables) on a WEB interface to the operator.

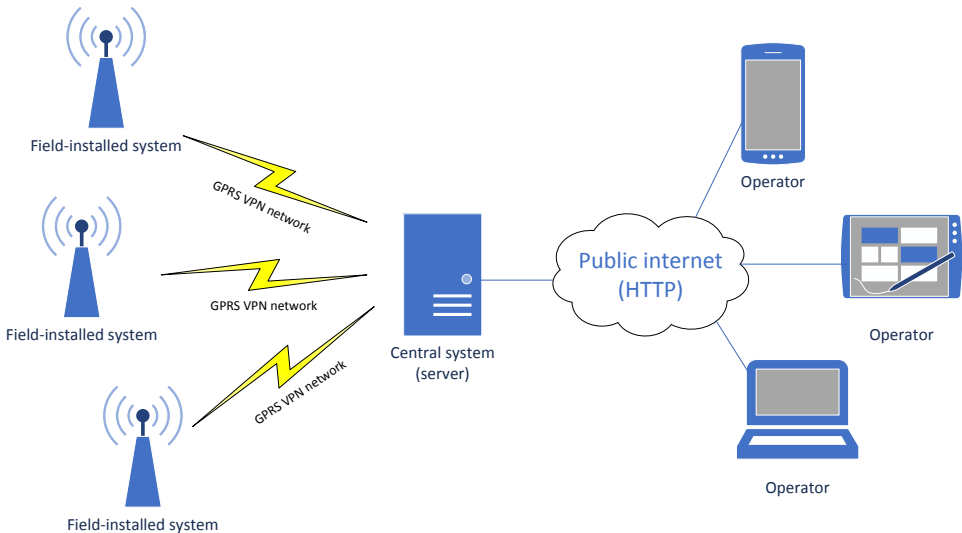

Figure 3. IT system architecture

The remote system can work completely autonomously. It is made up of the following important components:

- the Remote Terminal Unit (RTU) is a programmable logical controller, which can work away from the central unit;
- GSM modem is a very important part of the system, because thanks to this device the system can communicate via the GPRS network with the central computer;
- local display, which shows data on site;
- buttons, that's useful on local control;
- battery stores the energy, that is necessary to supply the system if it is a field-installed system;
- solar panel to charge the battery (during the day these panels charging the battery);
- solar charge controller to prevent overcharging and protect against overvoltage.

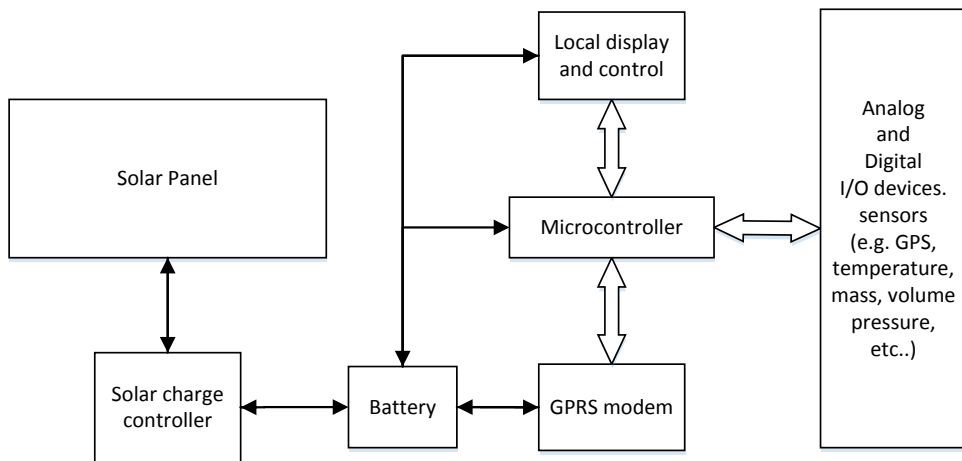

Figure 4. Components of the remote system

4.2. How it works? A Real-Time Operation System is running on the RTU. It is programmable in ANSI C++. The RTOS supports the multithreaded programming that we are using in this application. The program of the RTU is running on 5 parallel threads. These threads are responsible for:

- data acquisition and storage into the local non-volatile memory;
- data communication, the data is reached safely the central server via GPRS network;
- calculating data to the local display, and handling local input buttons (to local control);
- monitoring input values and if one of it reached a previously configured limit, then alerting the central system;
- the main thread, it reads the configuration file, starts the other threads and monitor the internal operation of the controller.

Thanks to the multithreaded environment the system can work with different timing periods. When the controller starts, the first step is to read the configuration file. This file

consists of 4 sections. The first section, named “Network” describes the configuration to use the GPRS network. It contains the following key-value pairs:

- APN – name of the access point that we want to use (it depend on the supplier);
- PIN – code for the SIM card;
- Address – the central server address, which is ready to receive data;
- Attempts – this key is a limit that specifies the maximum number of data sending retries in one communication period. If it reached, then the data is sent only the next communication period.

The second section in the configuration file is responsible for internal timing settings. It contains settings to the following:

- measurement – it is the data backup interval;
- communication – it specifies a time, which if passed, the collected data is sent.

The “Limits” section describes the limit values for the input channels of the controller. This section has rows in the following format: LOLO LO HI HIHI, which means the value of the channel is very low, low, high and very high (e.g. temperature, pressure). So in the system can be specified 4 limit values for each analogue input channel. For the digital channels can be specified 2 limits: one for the rising edge and one for the falling edge (e.g. door opening, switches or buttons). When the limit occurs the controller starts communicating immediately.

In the last section the operator can configure the following keys:

- alerts – if this value is “1”, the controller send alerts when a configured limit is reached;
- log – the key specify that the program is logging the operations. It is used to debugging the program under the development phase.

In order to save energy the modem is sleeping default. It wakes up only when communication is required. The configurable data sending interval is an energy efficiency factor also. When the configured communication time is greater, the modem is switched on rarely.

On the central server, the incoming data is received and processed by a pre-processing script. First of all the script checks the CRC code at the end of UDP packets. If it is not correct, the packet is dropped. If the CRC code in the packet is equals with the server calculated, the packet arrives correctly. There are two types of packets: data packet or alert packet. If the packet is a data packet it consists of sensor data and is stored in the database. If the packet is an alert, the processing script sends warnings (E-mail or SMS) before storing.

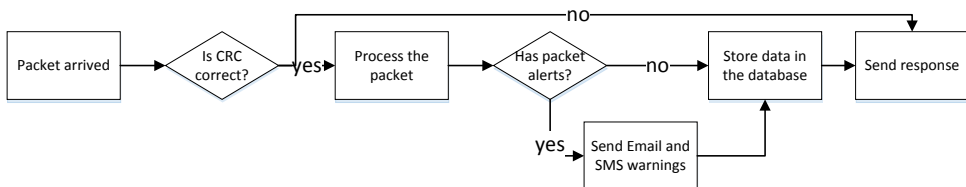

Figure 5. Flow chart of the server side pre-processor script

If the data stored successfully, verification is sent to the remote system. The remote system stores data while the verification message has arrived.

The website that shows the operation of the remote systems is accessible for authenticated users only. It is necessary because this information is important and private. After login, on the website is accessible all of the received data in the format of tables, charts and downloadable in text, excel and pdf format.

On the website, administrators can configure the remote system. On the configuration page, they can modify the configuration file remotely. When the remote system send data, the server with the verification message in the response sends the controller configuration also. After the remote system received the new configuration file, it reloads its configuration and continues to operate according to the new configuration file.

5. Summary

This paper presented the conception of GPRS based remote monitoring system to support decision making processes of logistic systems. The implementation of the system includes the field-installed system, the GPRS VPN network, the central server, public internet (http) and operators. The remote system includes a PLC, a GSM modem, local display, keyboard, batteries, solar panel and solar charge controller. The developed system can be integrated into the ERP. By the aid of this system it is possible to collect information from suppliers and customers of the supply chain; real-time decisions can be supported.

Acknowledgements

This research was partially carried out in the framework of the Center of Excellence of Mechatronics and Logistics at the University of Miskolc.

Literature

- [1] Cselényi, J.; Illés, B. (2006) *Logistic systems (in Hungarian)*. University Press Miskolc
- [2] Telek, P. (2011) *Characteristic solutions of material flow systems*. Advanced Logistic Systems. Theory and Practice, Vol. 5 pp. 57-62. HU ISSN 1789-2198
- [3] Gubán, Á.; Kása, R. (2013) *A Literature Based Review of Business Process Amelioration Methods and Techniques Regarding Service Orientation*. Journal of Advanced Management Science, Vol. 1(2) pp. 230-235.
- [4] Erturgut, R. (2012) *The future of supply chain and logistics management in the strategic organisations: contractor companies and new generation suppliers*. Procedia Social and Behavioral Sciences, Vol. 46(1) pp. 4221-4225. doi: 10.1016/j.sbspro.2012.06.230
- [5] Prajogo, D.; Olhager, J. (2011) *Supply chain integration and performance: the effect of long-term relationships, information technology and sharing, and logistics integration*. International Journal of Production Economics, Vol. 135(1) pp. 514-522. doi: 10.1016/j.ijpe.2011.09.001
- [6] Islam, D. Z.; Meier, J. F.; Aditjandra, P. T.; Zunder, T. H.; Pace, G. (2012) *Logistics and supply chain management*. Research in Transportation Economics, Vol. 41(1) pp. 3-16. doi: 10.1016/j.retrec.2012.10.006
- [7] Soleimani, H.; Govindan, K. (2014) *Reverse logistics network design and planning utilizing conditional value at risk*. European Journal of Operation Research, Vol. 237(2) pp. 487-497. doi: 10.1016/j.ejor.2014.02.030

- [8] Musa, A.; Gunasekaran, A.; Yusuf, Y.; Abdelazim, A. (2013) *Embedded devices for supply chain applications: Towards hardware integration of disparate technologies*. Expert Systems with Applications, Vol. 41(1) pp. 137-155. doi: 10.1016/j.eswa.2013.07.017
- [9] Antunes, F.; Melo, P.; Costa, J. P. (2007) *Information management in distributed collaborative systems: The case of collaboration studio*. European Journal of Operational Research, Vol. 177(1) pp. 1385–1399. doi: 10.1016/j.ejor.2005.04.010
- [10] Mingxiu, Z.; Chunchang, F.; Minggen, Y. (2012) *The Application used RFID in Third Party Logistics*. Physics Procedia, Vol. 25(1) pp. 2045-2049. doi: 10.1016/j.phpro.2012.03.348
- [11] Lee, C. K. M.; Ho, W.; Ho, G. T. S.; Lau, H. C. W. (2010) *Design and development of logistics workflow systems for demand management with RFID*. Expert Systems with Applications, Vol. 38(5) pp. 5428-5437. doi: 10.1016/j.eswa.2010.10.012
- [12] Prasanna, K. R.; Hemalatha, M. (2012) *RFID GPS and GSM based logistics vehicle load balancing and tracking mechanism*. Procedia Engineering, Vol. 30(1) pp. 726-729. doi: 10.1016/j.proeng.2012.01.920
- [13] Chai, N.; Yeo, B. S.; Chew, Y. H. (2005) *Location management for GPRS*. Computer Networks, Vol. 50(15) pp. 2888-2901. doi: 10.1016/j.comnet.2005.10.015
- [14] Dehua, W.; Pan, L.; Bo, L.; Zeng, G. (2012) *Water quality automatic monitoring system based on GPRS data communications*. Procedia Engineering, Vol. 28(1) pp. 840-843. doi: 10.1016/j.proeng.2012.01.820
- [15] Wang, X.; Ma, L.; Yang, H. (2011) *Online water monitoring system based on Zigbee and GPRS*. Procedia Engineering, Vol. 15(1) pp. 2680-2684. doi: 10.1016/j.proeng.2011.08.504
- [16] Jie, L.; Yunfeng, H.; Wenjun, Z.; Xiaojun, L. (2012) *Investigation on remote monitoring system for heat-supply thermal characters based GPRS*. Procedia Environmental Sciences, Vol. 12(2) pp. 843-850. doi: 10.1016/j.proenv.2012.01.357
- [17] Zhuo-Yi, C.; Huei, L.; Miao-Miao, W. (2012) *Design of portable checking and ticketing systems based on GPRS*. Procedia Engineering, Vol. 29(1) pp. 4002-4006. doi: 10.1016/j.proeng.2012.01.609
- [18] Bányai, Á. (2013) *How to support purchasing with ERP systems as integrator of novel logistic tools?* Advanced Logistic Systems. Theory and Practice, Vol. 7(1) pp. 7-12.
- [19] Krigsman, M. (2013) 2013 ERP research: *Compelling advice for the CFO*. www.zdnet.com. Downloaded 20/04/2014
- [20] N. N. (2014): *Enterprise resource planning*. www.wikipedia.com. Downloaded: 04/05/2014
- [21] Hendricks, K. B.; Singhal, V. R.; Stratman, J. K. (2007) *The impact of enterprise systems on corporate performance: A study of ERP, SCM, and CRM system implementations*. Journal of Operations Management, Vol. 25(1) pp. 65-82. doi: 10.1016/j.jom.2006.02.002
- [22] Seethamraju, R., Sundar, D. K. (2013) *Influence of ERP systems on business process agility*. IIMB Management Review, Vol. 25(3) pp. 137-149. doi: 10.1016/j.iimb.2013.05.001
- [23] Gubán, M. (2011) *Non-linear programming model and solution method of ordering controlled virtual assembly plants*. In: M. G. Ozerova, V. F. Lukinikh, A. N. Reznikova, N. A. Tod (eds.): Logistics - The Eurasian Bridge: Materials of V International scientifically-practical conference. Krasnoyarsk: Krasnoyarsk State Agricultural University. pp. 49-58.
- [24] Kota, L. (2012) *Optimization of the supplier selection problem using discrete firefly algorithm*. Advanced Logistic systems. Theory and Practice, Vol. 6(1) pp. 10-20. HU ISSN 1789-2198
- [25] Bányai, Á. (2012) *Intermodal optimization with harmony search*. Advanced Logistic Systems. Theory and Practice, Vol. 6(1) pp. 57-62. HU ISSN 1789-2198
- [26] Geum, Y.; Lee, S.; Park, Y. (2014) *Combining technology roadmap and system dynamics simulation to support scenario-planning: A case of car-sharing service*. Computers & Industrial Engineering, Vol. 71(1) pp. 37-49. doi: 10.1016/j.cie.2014.02.007